

Nani - Floating Dockleveller Type VBKS

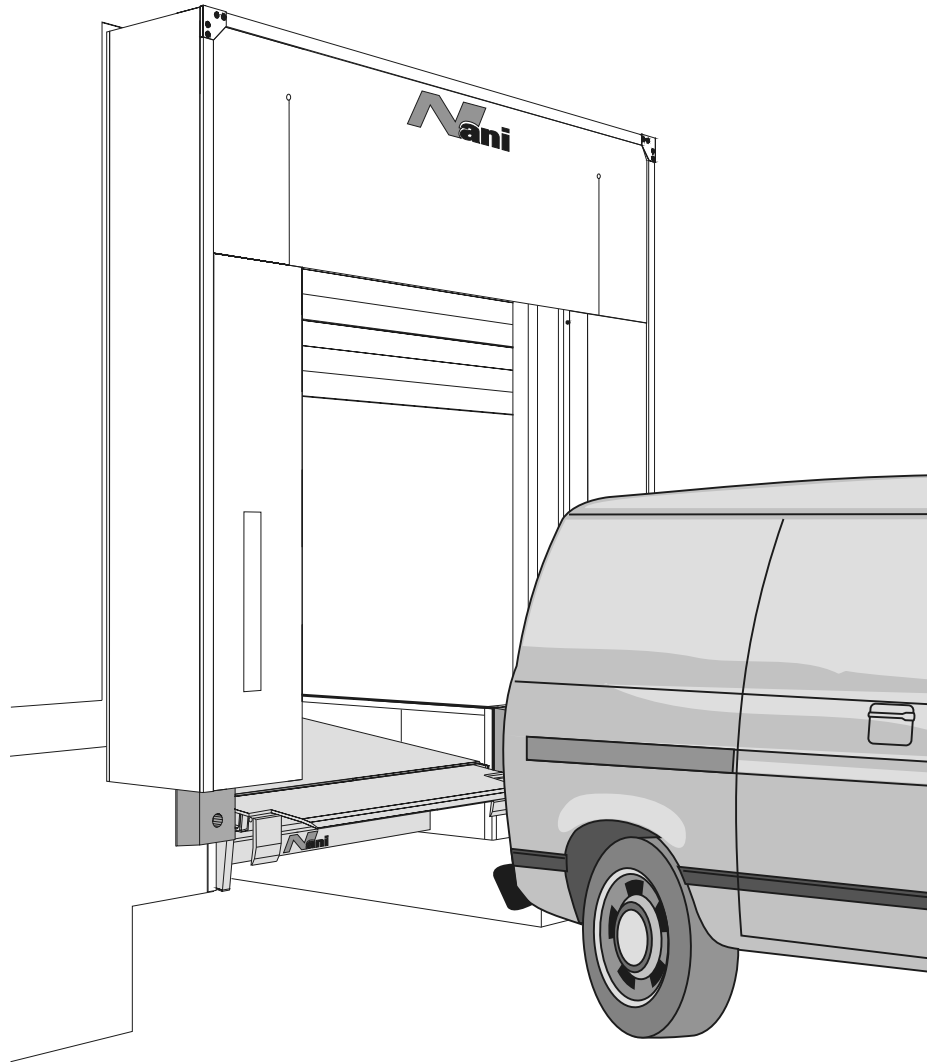

The Nani- Floating dockleveller Type VBKS is an all-purpose dockleveller. It is developed for the special case where a normal truck and a little van have to be loaded / unloaded. So it is used where varying vehicles have to be disposed.

A visible difference to a normal dockleveller is that the lip is three-parted. The external parts can be flapped down so that the lip fits into minor vehicles.

Another, invisible, difference is located in the hydraulic system. At the disposal of a little vehicle is it supposable that the weight of the plateau would overload it.

To prevent this you can enable the floating mode. Thereby gets the plateau weight 'hold off' by the hydraulic system. So the vehicle has to endure only a very light load that can be adjusted as required. This little load is necessary for the swimming-position of the leveller so that it is able to adjust the movements of the vehicle while the loading / unloading.

The capacity of the dockleveller can be achieved as the customer requires it and is similarly designed for cross-traffic. A hydraulic emergency-stop guarantees a stopping of the leveller in every position, also while the maximum load.

Changes to specification maybe made without prior notification.

SB1-9604-E

Nani
VERLADETECHNIK

...for optimal loading

<http://www.nani.de> E-mail: info@nani.de

Nani Verladetechnik GmbH & Co. KG
Siegerslebener Str. 12, D-39365 Eilsleben
Tel: (039 409) 914 0, Fax: (039 409) 345